



***baja designs***<sup>®</sup>  
THE SCIENTISTS OF LIGHTING

**Dodge, Ram 2500/3500 (10-18), 1500 (09-12), Squadron 2.0  
Sport, SAE Fog Pocket Kit  
44-0053, & 44-0054**



2950 Norman Strasse • San Marcos • CA • 92069

Phone 760-560-2252 • Fax 760-560-0383

info@bajadesigns.com • [www.bajadesigns.com](http://www.bajadesigns.com)



***baja designs***<sup>®</sup>  
THE SCIENTISTS OF LIGHTING

## LIMITED LIFETIME WARRANTY

Baja Designs proudly offers a LIFETIME WARRANTY against manufacturer's defect on all the products that we manufacture.

These are comprehensive warranties; other than the exclusions below – you're covered. If your LED or HID bulb burns out, you're covered. Additionally, cutting off our connector or changing your lenses does not automatically void your warranty.

### **Exclusions:**

Installation errors, abuse, misuse or crash damage. You must be the original owner of the product and can supply proof of purchase.

Baja Designs manufactures its own products as well as resells products manufactured by others. Baja Designs makes no express or implied warranties on products not manufactured by Baja Designs including without limitation any warranties or merchantability and fitness for a purpose. We will, however, pass on all warranties made by the manufacturer, who has sole responsibility for performing such warranties.

Baja Designs will pay the freight if your product is less than 90 days old, otherwise defective products must be returned to Baja Designs, Inc., freight prepaid. At our option, we will repair or replace items in question and return them at no charge. If the identical product is no longer available, we will replace with a similar product of equal value. Baja Designs Inc. will not be responsible for any indirect or consequential damages in connection with defective merchandise.

Items purchased through a Baja Designs authorized dealer must be returned through the dealer. Only available on LED auxiliary lights and product must be in sellable condition at MSRP. Product that has been damaged in any way after the original purchase date will be excluded from this guarantee.

### **Indemnification:**

**Buyer hereby acknowledges off-roading, racing and driving at night are dangerous activities and that the products and/or supplies purchased from Baja Designs are used in an inherently dangerous activity that may endanger life and limb; and in no event shall the seller, or seller's heirs and assigns, be held liable for consequential damages, nor shall seller's liability on any claim for damages arising out of or connected with the sale, delivery, or use of purchased products and/or supplies exceed the purchase price of the products and/or supplies.**

**Buyer is responsible for ensuring that it uses the products (and its vehicle) in accordance with all applicable laws, regulations, guidelines, and standards of care. Buyer acknowledges that some products may only be used when off-roading, and Buyer will comply with all vehicle and road safety guidelines. Buyer is solely responsible for (and will indemnify and hold Bestop harmless for) any claims, losses, damages, fines, fees, costs, or other amounts arising out of Buyer's non-compliance with these provisions.**

## **Tools Required**

\*12mm, 10mm, 9/16" socket      \*3/4" drill bit      \*Scissors  
\* 9/16" wrench

To begin, make sure the vehicle is in park, on level ground and the parking brake is engaged.

1. Start by unplugging the factory fog lights.

2. Using a 10mm socket, remove the 3 bolts per side (image 2 is the driver side). Once the bolts are removed, take the fog light assembly out and place it out of the way. They will no longer be needed in the assembly. Keep the 10mm bolts.



3. Using the provided hardware, attach the silver u-bracket to the lights as shown.

4. Once the u-bracket is attached to each light, proceed to attach the lights to the provided vehicle bracket. Using a 9/16 socket and a 9/16 wrench, attach the lights to the bracket. Attach the Squadron SAE on the outside and the Squadron 2.0 Sport on the inside.

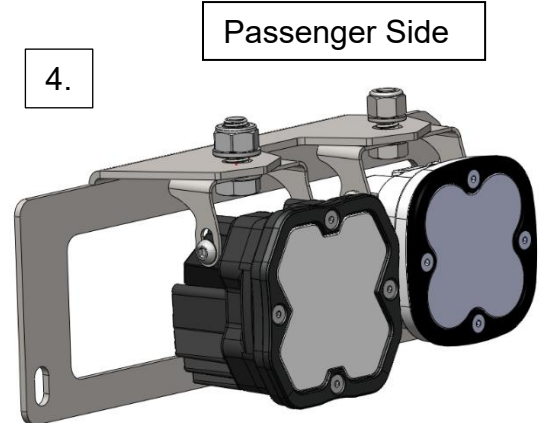
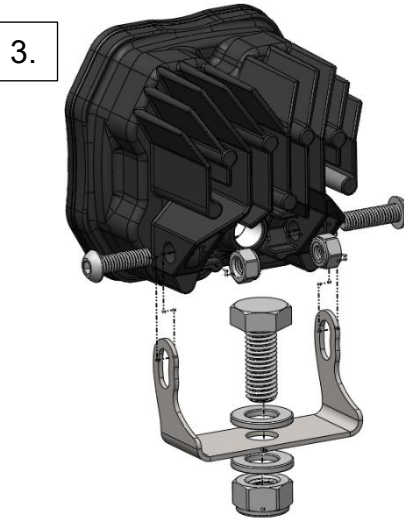

5. Now install the Baja Designs brackets and lights into the OEM location using the factory 10mm bolts (image 5 is the driver side).

6. Using the supplied wiring adapters, plug the Squadron SAE's into the factory OEM plug.



7. Locate the included wiring harness and mount the relay to the common ground using the mounting tab on the relay.

8. Run the switch lead along the firewall and to the wiring passthrough location.

7. & 8.



9. Select a location on the dash for the switch. Check for clearance behind the switch panel and drill a 3/4" hole for the switch.

10. Take a reference photo of the switch wiring. Disconnect the spade connectors and run the wires through the firewall and switch hole. Plug the switch back in and install it into the hole.

10.

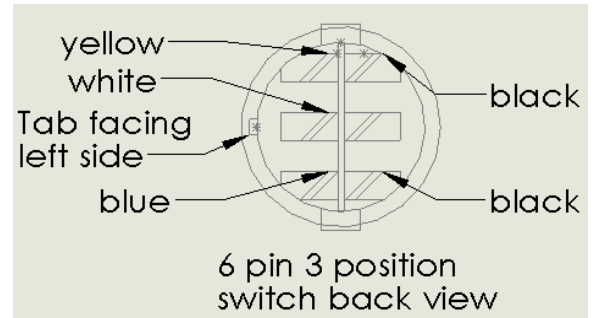

11. Using a 12mm socket, remove the negative battery cable. Connect the positive ring terminals to the positive battery wire. Repeat for the negative ring terminals to the negative battery wire and reconnect the negative cable.

12. Run the light connectors to both sides and plug in the Squadron 2.0 Sports.

\*Tie all wires away from sharp, hot, and/or rotating components.

\* Re-torque all the fasteners after 100 miles.

\*Your install is now complete! Thank you for choosing Baja Designs.

## Backlight add-on harness instructions for Squadron 2.0

**Note:** Included with this harness is four fuse taps. In the event that none will work for your application, a splice connector is included (shown on right).

1. Locate the fuse panel in the engine compartment. Remove cover.
2. Observe the inside of the fuse box cover, or the owner's manual to determine fuse locations and functions. The goal is to find a suitable circuit that is powered on when the vehicle is turned on. It is important to choose a fuse location that does not power sensitive electrical components, such as sensors and ignition modules. Choose a fuse that is activated by turning the key and remains active while the vehicle is starting and running. The IGN fuse is highly recommended for this. Using other circuits to run the backlight may result in the color changing when not desired.
3. Once the fuse location has been chosen, the multimeter or test light will be used to determine which side of the fuse is power and which side is the output. Using either tool, touch the positive test lead to one side of the fuse socket and touch the negative lead to the negative battery post, or any convenient ground. With the keys in the off position, neither side of the fuse socket should have power. If they do, another fuse location will need to be chosen.
4. Now, turn the keys to the on position and measure each side of the fuse socket. When the test light illuminates, or the multimeter DC voltage measures 12-14V, the power side of the fuse has been determined. Insert the fuse tap into the socket with the arrowed side blade (shown in image ii) contacting the power side. Plug in the backlight harness to the female bullet receptacle of the fuse tap. If the fuse socket originally had a fuse, place it into the open socket on the fuse tap.
5. Every fuse panel is different and sometimes there are adjacent components that make it difficult or impossible to plug in a fuse tap. In this case, the splice connector will need to be used. Find a wire that is powered when the keys are on. Ideally, this wire would power the daytime running lights and not an electrically sensitive component like a sensor. With the backlight harness inserted into the female bullet receptacle of the splice connector, clasp the splice over the desired power wire and clamp with pliers until an audible click is heard. (See image iii for reference)

### Tools Required

- Trim Tool (Or Flathead Screwdriver)
- Scissors
- Test Light, or Multimeter

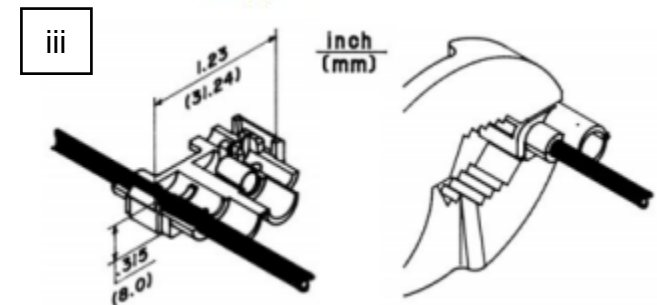
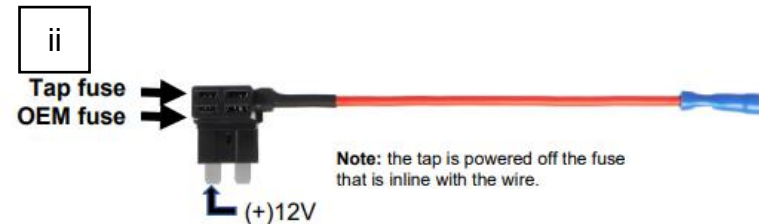

Fuse tap kit part #: 63-9209

## Backlight add-on harness instructions

6. Use the provided 5-amp fuse in the fuse tap for the backlight add-on harness (See image ii for reference).
7. Remove the Wedge lock from the plug by using a flat head screwdriver and **gently** prying along the edges with a flathead to release the lock (see image v for reference)
8. Locate the backlight add-on harness supplied in the kit. If a cavity plug was inserted previously in the PnP (Plug-n-Play) adapter, please remove it and insert the terminal inside the (3) pin location. (See image vii for reference)
9. To reinstall the wedge lock, simply push the wedge lock back in until it clicks in. (See image v for reference)
10. Determine the best routing for the backlight add-on harness.
11. Connect the bullet connector from the backlight add-on harness to the fuse tap and secure the wire harness. (Use image iii for reference)
12. Turn on the vehicle and test to see if the backlight function on the Squadron 2.0 works appropriately.
13. Use included zip ties to tie the harness out of the way of any hot and/or rotating components.

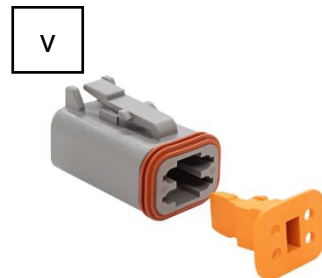
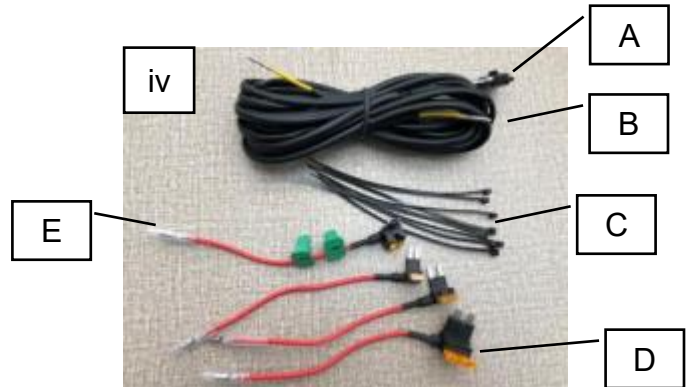

A: Splice connector  
 B: Harness  
 C: Zip ties  
 D: Fuse taps  
 E: Bullet connector

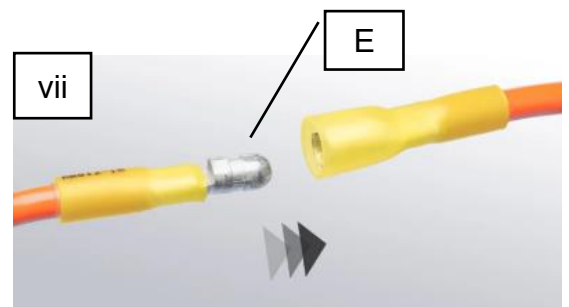
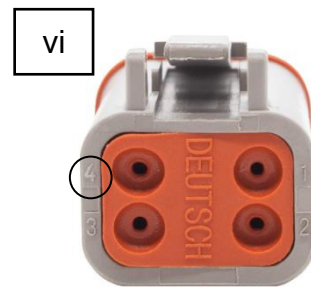

## Backlight switch adapter instructions

1. Connect the bullet connectors from the switch inline between the fuse tap and the backlight add-on harness.
2. Turn the switch on and off until the desired color is displayed as the backlight.
3. Once the desired color has been achieved, the switch can be either removed or left in. To remove the switch, turn the vehicle off and remove the switch. Reconnect the bullet connectors between the fuse tap and the backlight add-on harness. To leave the switch in line, secure the switch so it does not move. **Be sure to always leave switch in the “on” position if the switch will be left in.**



Inline switch part #: 60-0071